

**Fully Integrated Booster Pump Station**

## Commercial & Industrial Booster Pump Station

Pump Solutions is a leading manufacturer of HVAC and Plumbing Packaged Systems. All of our systems are custom engineered, manufactured and tested in our Hollywood, Florida USA facility.

Pump Solutions “Long-term partnership” keeping a high level of customer service and technical support long after the sale has been completed.

**CALL PSI TODAY!**

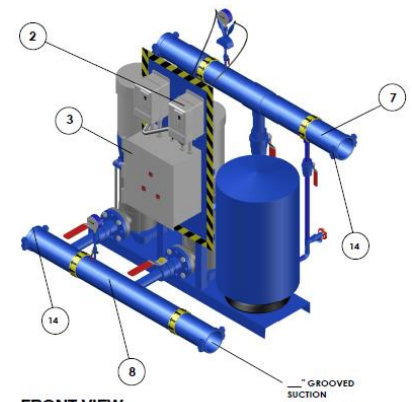
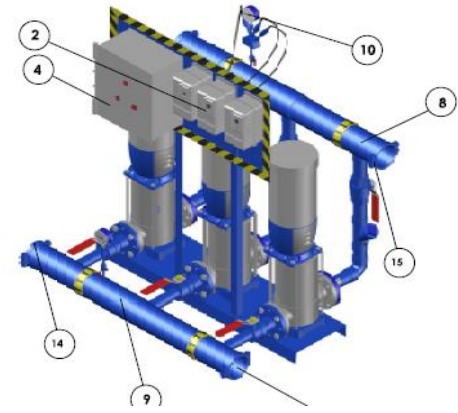

### At-A-Glance System Description:

Mechanical:

- Max Hydraulic capabilities of 1500 GPM and up to 340 PSI.
- Centrifugal Bronze-fitted / Stainless Steel Pumps, NSF 61 Certified
- Vertical Multistage 304 Stainless Steel Pumps, NSF 61 Certified
- All ANSI Flanged or Grooved Design
- 304 Stainless Steel Header Pipe
- 304 Stainless Steel Impellers
- All Valves, NSF 61 Certified
- Heavy Duty Steel Base & Panel Stand
- Industrial Enamel Coated
- Copper Type 'L' Manifolds 2", 3", 4", 6", 8"
- 304/316 Stainless Steel Manifolds 2", 3", 4", 6", 8"

Electrical/Controls:

- UL 508A Listed Control Panels
- Variable Frequency or Constant Speed Controls
- PLC with Ethernet Capability, Building Communication (BACnet, LONWORKS, ++)
- 316 Stainless Pressure Transducers
- One Suction Transducer
- Automatic Pump Alternation
- Single Point of connection
- Main Electrical Disconnect
- NEMA Type 1, 12, 3R, 4 & 4X Panel Enclosures

Standards:

- Single Source Responsibility
- Simplex, Duplex, Triplex, and Quadraplex configurations
- Temporary Pump Station Available
- Factory Tested
- Completely customizable to meet the application.
- Factory Tested to Design Conditions



## MARKETS

- Commercial Plumbing
- Municipal
- Institutional
- Process
- Industrial